

## MODEL SLD-2 GAS DETECTOR DUAL CHANNEL (TWO GASES)

### GENERAL DESCRIPTION

The Acromet Model SLD-2 Dual Channel Gas Detector is a state-of-the-art, microprocessor controlled instrument capable of detecting Chlorine, Sulphur Dioxide, Ammonia, and Ozone gasses at levels far below the threshold of human awareness. Acromet Dual Point Gas Detectors are an "operator friendly" and economical way to protect personnel and property. The detector will individually monitor any two listed gas levels, or two separate locations of the same gas, well below OSHA requirements, and activate warning devices when threshold levels are reached.

The Model SLD-2 Dual Channel Gas Detector consists of a Controller/alarm module, and two remote gas sensor modules which can be located up to 305 meters away (1000 feet) from the controller. The sensors respond immediately to the presence of gas, and recovers very quickly when the gas has cleared. The controller/alarm module is housed in a NEMA-4X enclosure. Many features which are extra cost options in other gas detectors are standard with the SLD-2.

### FEATURES

- User-friendly key pad interface with functions indicated by individual menu display screens.
- 16-character by 2-line display, with green LED back light for easy reading, even in low light areas.
- NEMA-4X controller enclosure.
- 95 dB internal alarm horn.
- Event alarm log records up to 256 events, with time and date, which can be viewed on the display or downloaded from the optional serial port.
- Sensor life and calibration reminder timers.
- Sensor life and calibration reminder timers.
- 4-20 mA gas level monitor output.
- Password protection for all parameter settings.
- High, Low, Latching and Non-Latching alarm relays.
- Two level alarm settings for "Warning" and "Danger" gas levels.
- All alarm relays are user adjustable for N/O, N/C, Latch or Non-Latch.
- Flashing backlight screen when alarm acknowledgement is required.
- Remote alarm acknowledgement of any alarms up to 76 meters (250 ft) from the controller.
- Individual, real-time display of each monitored gas level.

### APPLICATION

The Acromet Model SLD-2 is designed for use in:

- Wastewater treatment plants
- Water purification plant
- Swimming pools

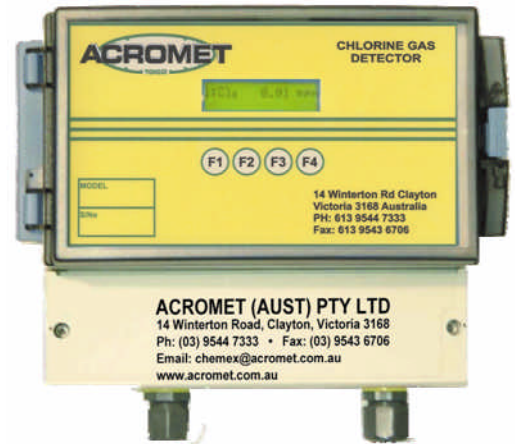

## APPLICATION continued

- Cooling towers – air scrubbers
- Food and beverage processing
- Chemical processing

Acromet design provides ease of operation with top performance. The Acromet Series SLD-2 Dual Channel Gas Detector can be placed where most convenient for the operator for ease of use while the gas sensor can be placed in the monitored environment up to 305 meters (1000 feet) away.

Materials used in manufacturing the Acromet Series SLD-2 Dual Channel Gas Detectors have been carefully selected for their superior quality and performance in situations and conditions far more extreme than conditions to be encountered in actual use.

## AVAILABLE OPTIONS

- Internal Battery backup with charger. An external UPS may also be used to allow full function operation over extended power outages.
- RS232 serial port for downloading data.

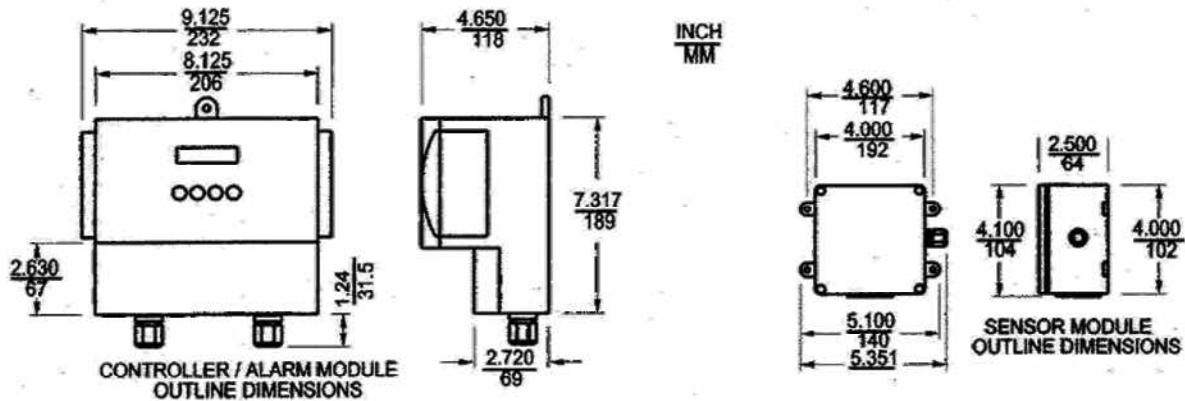
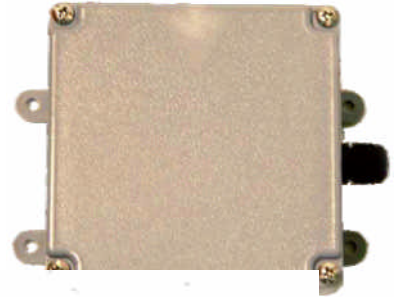

## TECHNICAL SPECIFICATIONS

Sensor Inputs (Analogue Inputs)		Relays & I/O	
Maximum Number of Gas Sensors:	Two	Type:	Form-A (N/O)
Gas Sensor Signal:	Current Loop (4-20 mA)	Maximum Current Rating:	5A (resistive)
Loop Voltage::	15V, short circuit protected	Suppression:	275V, 10J, MOV
Maximum Sensor Distance:	305 meters (1000 feet)	Voltage:	250VAC / 30 VDC
Sensor Outputs (Analogue Outputs)		Quality:	5 (2 Danger, 2 Warning, 1 Alarm)
Signal Type:	4-20 mA	Remote Acknowledgement Switch:	Yes
Voltage Compliance:	12 V	Horn Output:	Yes: 10-24V
Maximum Load:	600?		
Minimum Load:	0?		
Number of Outputs:	Two	Power Supply	
Computer & Display		A.C. Line Voltage (115V):	85V – 130V
Microcontroller:	68HC12 type	A.C. Line Voltage (230V):	170V – 250V
ROM:	128K, FLASH	Power:	12W
ROM upgradable in Field:	Yes	Optional D.C. Supply:	Sealed NiMH
Real-time Clock:	Yes		
RS232 Port:	2 (one standard, one optional)	Environmental	
Display:	LCD, 2-Line, 16 char./line, backlit	Operating Temperature:	0°C to 50°C (32°F to 122°F)
Pushbuttons:	Four, tactile dome type	Humidity:	2%, non-condensing

## Acromet (Aust) Pty Ltd

14 Winterton Road, Clayton, Victoria 3168  
 Ph: (03) 9544 7333 • Fax: (03) 9543 6706  
 Email: [chemex@acromet.com.au](mailto:chemex@acromet.com.au)

Suite 302, 63-79 Parramatta Road, Silverwater, NSW 2128  
 Ph: (02) 9647 2432 • Fax: (02) 9647 2599  
[www.acromet.com.au](http://www.acromet.com.au)