

DMS 302 – DUAL CYLINDER SCALE

The Acromet Model DMS302 is a mechanically actuated dual cylinder scale for weighing compressed gas cylinders such as for chlorine and sulphur dioxide. It is a true high accuracy scale with a three-beam linkage system. The scale has two independent, solid PVC weighting platforms with dedicated, high-resolution indicators and mechanical tare adjustments. Materials of construction have been selected to ensure optimum in corrosion resistance in the harsh water and wastewater treatment and industrial chemical feed environments. The DMS302 is the standard of the industry in cylinder weighing and is suitable for any compressed gas cylinder application within its dimensional and weight limitations.

FEATURES

- Large, easy to read display, 20% larger than competing units.
- Post-mounted support bracket and safety chains – standard.
- Designed for hostile, high corrosion environments.
- Solid PVC scale base is warranted for 5 years.
- No special tools required for installation.

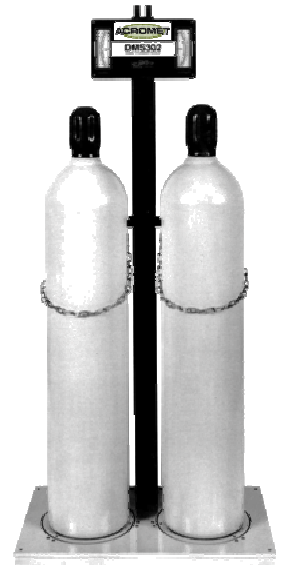

OPERATIONS

Its low profile makes it easy to roll cylinders onto the platforms without lifting. The cylinders are secured using a post-mounted bracket and safety chains which are included with the scale. A simple, mechanical tare adjustment is made using the independent adjusting knobs on the indicator head. The net weight is then transmitted to the large, 12.7 cm, high-resolution analogue indicator via a time proven, high reliability lever system. The indicator reads the weight remaining in each cylinder to a true +/- 1% of full scale accuracy.

FLEXIBILITY

The DMS302 is a mechanical dual cylinder scale designed to weigh 68 kg chlorine and sulphur dioxide cylinders. However, it can be used to weigh any compressed gas cylinder 30.5 cm or less in diameter and weighing up to 163 kg gross weight. Short cylinders can be accommodated by adjusting the height of the post-mounted support bracket.

DISPLAY

The weight of each platform is displayed on a separate, 12.7 cm long analogue scale which displays the value of weight remaining to a resolution of 0.5 kg. The indicator, typically graduated 0 – 68 kg, can be calibrated in metric units at no additional cost.

WARRANTY

Because of our confidence in the rugged design of this scale, Acromet warrants the entire scale against defects in material and workmanship for one year from date of startup. In addition, the scale base is warranted against damage from exposure to corrosive environments for a total period of 5 years.

ORDERING INFORMATION

- Scale calibration kg

PHYSICAL SPECIFICATIONS

Capacity	162kg per platform
Overload Capacity	150% Rated Capacity
Accuracy	+/- 1% FS
Cylinder Size	30.5 cm diameter max.
Display Calibration	0 – 68 kg
Display Resolution	0.5 kg
Operating Temperature Range	0 – 49°C

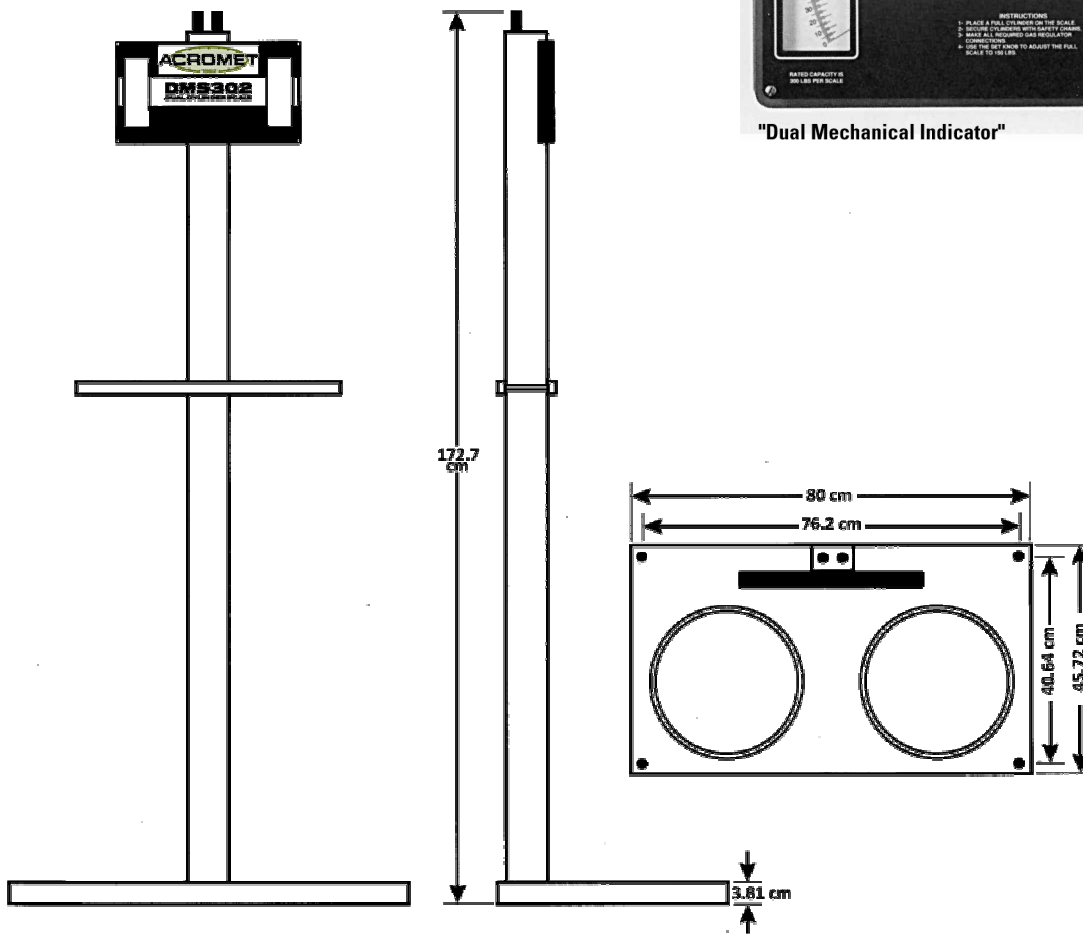

"Dual Mechanical Indicator"